

mideco *Bat Booth*

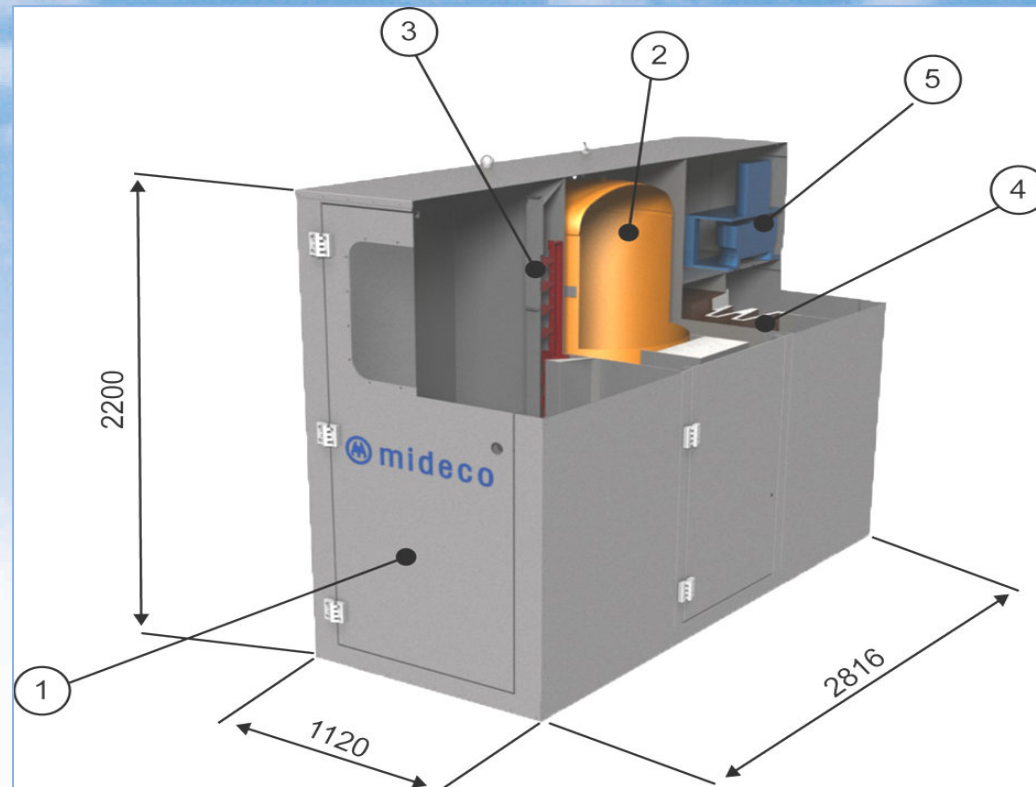

***Bat Booth* Components:**

- (1) The Cleaning Booth
- (2) Air Reservoir
- (3) Air Spray Manifold
- (4) Dust Filter
- (5) Exhaust Fan

Requirements

For installation only two connections are required:

- Compressed air to receiver
- 3 phase power to control cabinet

Filter Classification Standard

The dust filters used in the *Bat Booth* are in accordance to the following standards:

- European: EN779 (2012) = F9
- American Equivalent, MERV Rating = 15



Head Office and Manufacturing

1/158 Canterbury Road, Bayswater,
Victoria, Australia, 3153
Tel: 1300 854 085 Fax: 1300 856 085

Email: sales@mideco.com.au
www.mideco.com.au

mideco *Bat Booth*



Your partner in Environment Technology



Background Information

Dusty work clothes increases a worker's exposure to respirable dust. Respirable dusts are particles considered to have an aerodynamic diameter of 10 microns or less and able to enter and deposit into the gas-exchange region of the human lung. A study has found that once clothes become contaminated, they are a continual dust source until cleaned and create a 10-fold increase in worker dust exposure.

Mideco's Solution

Mideco Dust Control have developed a quick, safe and effective clothes cleaning method, where workers at various processing operations can clean their dust soiled clothing periodically throughout the workday. The Mideco De-dusting *BatBooth* uses low compressed air to safely clean the contaminated clothing. This method of cleaning takes only 10 - 12 seconds and removes 50% more dust than the commonly used single point air hose method.

Safety

The following safety features have been included into the *Bat Booth*:-

- Dual start buttons to prevent accidental start.
- Stop button to shut off compressed air flow.
- Low vacuum in the booth to ensure the door can be opened when the fan is running.
- Adjustable height of compressed air jets to block air from being directed above shoulder height.
- PPE signage – PPE requirements are dust mask and eye & ear protection at a minimum due to the compressed air and airborne dust.
- Light inside dust booth.
- Low voltage electrics for control, lighting and instrumentation.

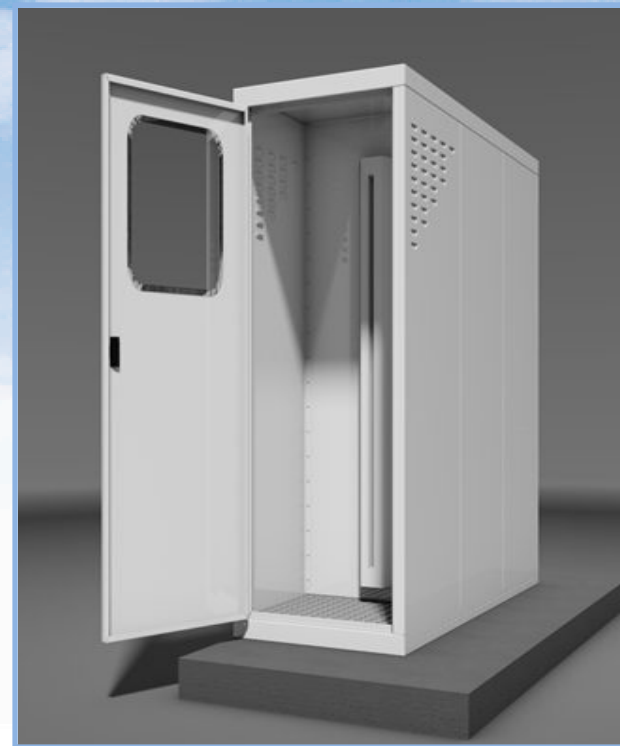

Modelled views of Mideco *Bat Booth*



Some applications for use:

- Industrial Minerals Processing
- Silica Processing
- Lead Recycling
- Metal Refining
- Powder Coating Processes
- Copper Smelting Operations
- Mineral Mining Operations
- Healthcare Industries
- Quarries
- Cement Processing Plants
- Wood Working Companies
- Textile Plants
- Construction Sites
- Auto Repair Shop



The Cleaning Process

The dust collector fan draws clean air into the booth through louvers mounted on the side panels. Simultaneously the compressed air jets blow the dust off the person's clothing as they turn around slowly. The compressed air and dust are then carried with the clean air to the dust collector.

During operation, the booth is maintained under negative pressure at all times. This ensures that all of the dust removed from the worker's soiled clothing, is contained within the cleaning booth and captured by the dust collector before the air is exhausted.

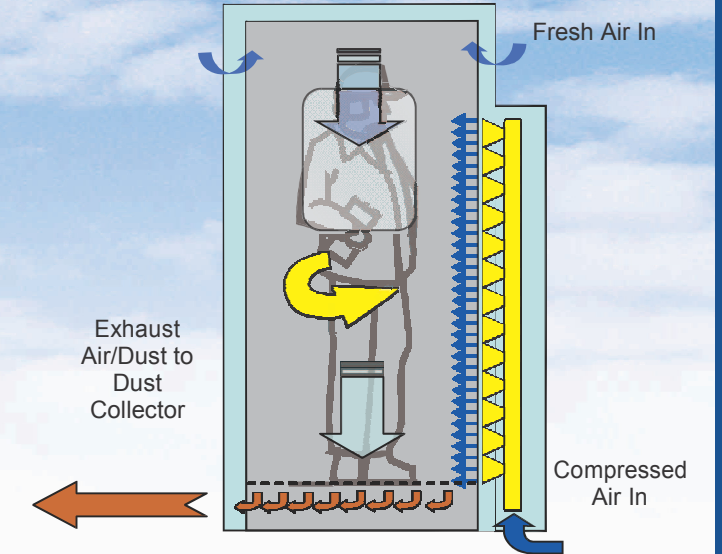

Before Process



During Process



After Process

